

剖面A-A

NOTES:

1. MATERIAL:

BODY: LCP, WHITE, UL 94V-0  
 COVER: PA, BLACK, UL 94V-0  
 TERMINAL: C5210, T=0.15mm  
 PEG: C5210, T=0.15mm

2. FINISH:

TERMINA: 50u" MIN Ni UNDER PLATING OVER ALL  
 1~3u" Au ON CONTACT AREA  
 PEG: 50u" MIN Ni UNDER PLATING OVER ALL  
 TIN 60-200u" PLATED ON SOLDER TAIL AREA

3. ALL DIMENSIONS MARKED ▼ MUST BE CONTROLLED BY QC

4. ALL DIMENSIONS MARKED ⊕ MUST BE CONTROLLED BY FAI

|      |         |             |            |                       |                     |             |          |                                      |
|------|---------|-------------|------------|-----------------------|---------------------|-------------|----------|--------------------------------------|
|      |         |             |            | UNITS:<br>mm          | GENERAL TOLERANCE   |             | DRAW:    | PART NO:<br>ZF2-ABXXF10A             |
|      |         |             |            | DATE:<br>06/07/2018   | X. ±0.25            | X' ±3.00'   | CHECKED: | TITLE:<br>0.50mm Pitch 1.0H ZF CONN. |
|      |         |             |            | SCALE:<br>20 / 1      | X ±0.20             | X' ±2.00'   | APPROVE: | DRAWING NO:                          |
|      |         |             |            | SHEET:<br>1 / 2       | .XX ±0.15           | .XX' ±1.00' |          |                                      |
| A    | -----   | NEW         | 06/07/2018 | MATERIAL:<br>SEE NOTE | .XXX ±0.10          |             |          |                                      |
| REV. | ECN NO. | DESCRIPTION | DATE       | REV. A                | FINISH:<br>SEE NOTE |             |          |                                      |



昆山捷皇电子精密科技有限公司  
 HONGRIDA ELECTRONIC TECHNOLOGY CO., LTD.

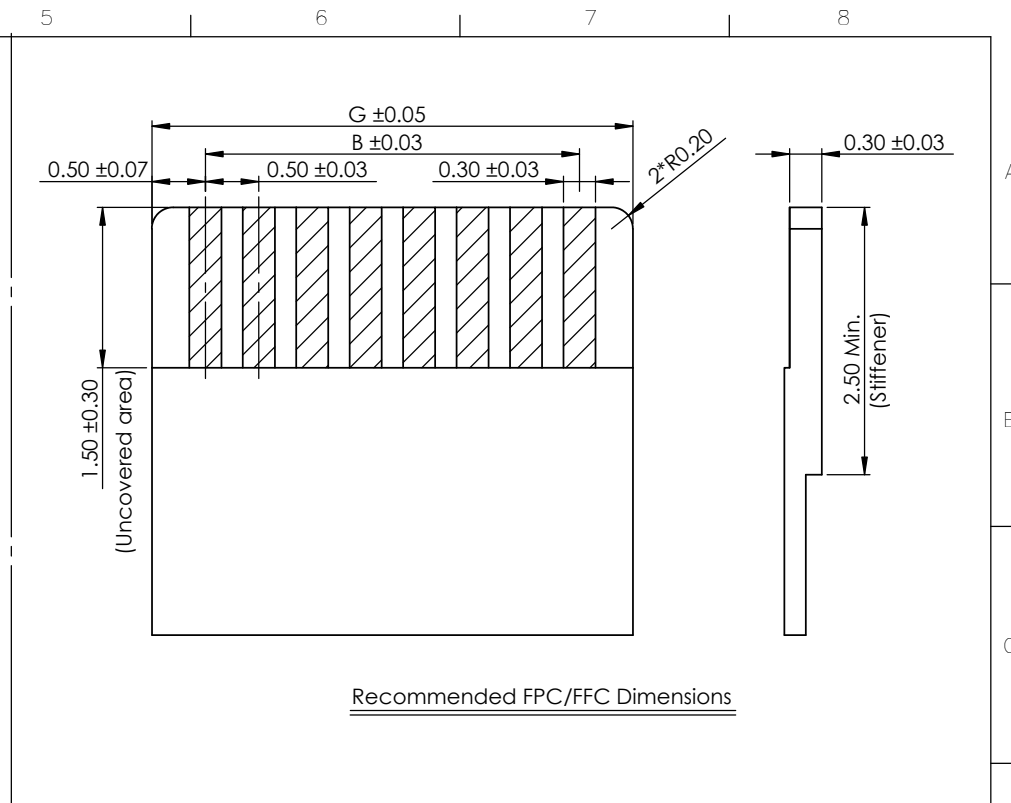
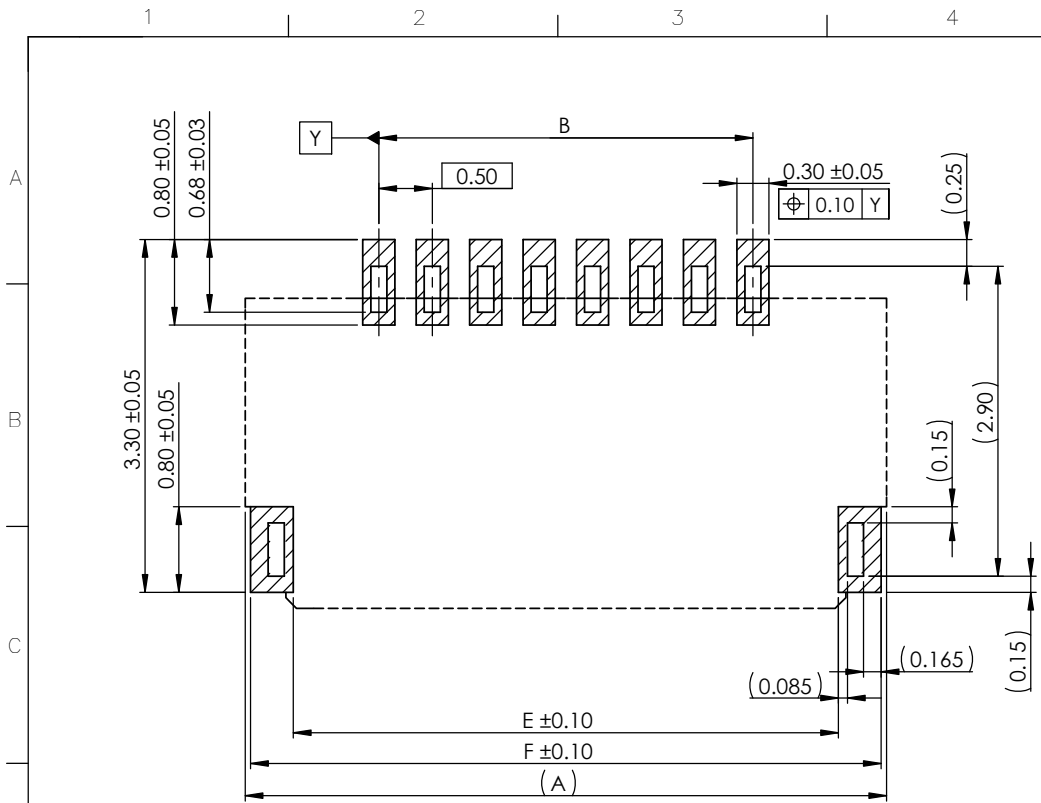

| (N)                | N*0.5+2.0 | (N-1)*0.5 | N*0.5+0.57 | N*0.5+1.39 | N*0.5+1.1 | N*0.5+1.9 | N*0.5+0.5 |
|--------------------|-----------|-----------|------------|------------|-----------|-----------|-----------|
| 50                 | 27.00     | 24.50     | 25.57      | 26.42      | 26.10     | 26.90     | 25.50     |
| 40                 | 22.00     | 19.50     | 20.57      | 21.42      | 21.10     | 21.90     | 20.50     |
| 34                 | 19.00     | 16.50     | 17.57      | 18.42      | 18.10     | 18.90     | 17.50     |
| 32                 | 18.00     | 15.50     | 16.57      | 17.42      | 17.10     | 17.90     | 16.50     |
| 30                 | 17.00     | 14.50     | 15.57      | 16.42      | 16.10     | 16.90     | 15.50     |
| 26                 | 15.00     | 12.50     | 13.57      | 14.42      | 14.10     | 14.90     | 13.50     |
| 24                 | 14.00     | 11.50     | 12.57      | 13.42      | 13.10     | 13.90     | 12.50     |
| 23                 | 13.50     | 11.00     | 12.07      | 12.42      | 12.60     | 13.40     | 12.00     |
| 22                 | 13.00     | 10.50     | 11.57      | 12.42      | 12.10     | 12.90     | 11.50     |
| 20                 | 12.00     | 9.50      | 10.57      | 11.42      | 11.10     | 11.90     | 10.50     |
| 16                 | 10.00     | 7.50      | 8.57       | 9.42       | 9.10      | 9.90      | 8.50      |
| 14                 | 9.00      | 6.50      | 7.57       | 8.42       | 8.10      | 8.90      | 7.50      |
| 12                 | 8.00      | 5.50      | 6.57       | 7.42       | 7.10      | 7.90      | 6.50      |
| 11                 | 7.50      | 5.00      | 6.07       | 6.42       | 6.60      | 7.40      | 6.00      |
| 10                 | 7.00      | 4.50      | 5.57       | 6.42       | 6.10      | 6.90      | 5.50      |
| 8                  | 6.00      | 3.50      | 4.57       | 5.42       | 5.10      | 5.90      | 4.50      |
| 7                  | 5.50      | 3.00      | 4.07       | 4.42       | 4.60      | 5.40      | 4.00      |
| 6                  | 5.00      | 2.50      | 3.57       | 4.42       | 4.10      | 4.90      | 3.50      |
| 4                  | 4.00      | 1.50      | 2.57       | 3.42       | 3.10      | 3.90      | 2.50      |
| Number of Contacts | DIM A     | DIM B     | DIM C      | DIM D      | DIM E     | DIM F     | DIM G     |

|      |         |             |            |                     |   |                                      |   |                                      |
|------|---------|-------------|------------|---------------------|---|--------------------------------------|---|--------------------------------------|
|      |         |             |            | UNITS:<br>mm        | GENERAL TOLERANCE                               |                                      | DRAW:   | PART NO:<br>ZF2-ABXXF10A             |
|      |         |             |            | DATE:<br>06/07/2018 | X. ±0.25<br>.X ±0.20<br>.XX ±0.15<br>.XXX ±0.10 | X." ±3.00<br>.X" ±2.00<br>.XX" ±1.00 | CHECKED:  | TITLE:<br>0.50mm Pitch 1.0H ZF CONN. |
|      |         |             |            | SCALE:<br>20/1      | MATERIAL:                                       |                                      | APPROVE:  | DRAWING NO:                          |
| A    | -----   | NEW         | 06/07/2018 | SHEET:<br>2/2       | FINISH:<br>SEE NOTE                             |                                      |  <b>昆山捷皇电子精密科技有限公司</b><br>HONGRIDA ELECTRONIC TECHNOLOGY CO., LTD. |                                      |
| REV. | ECN NO. | DESCRIPTION | DATE       | REV.                |   |                                      |   |                                      |

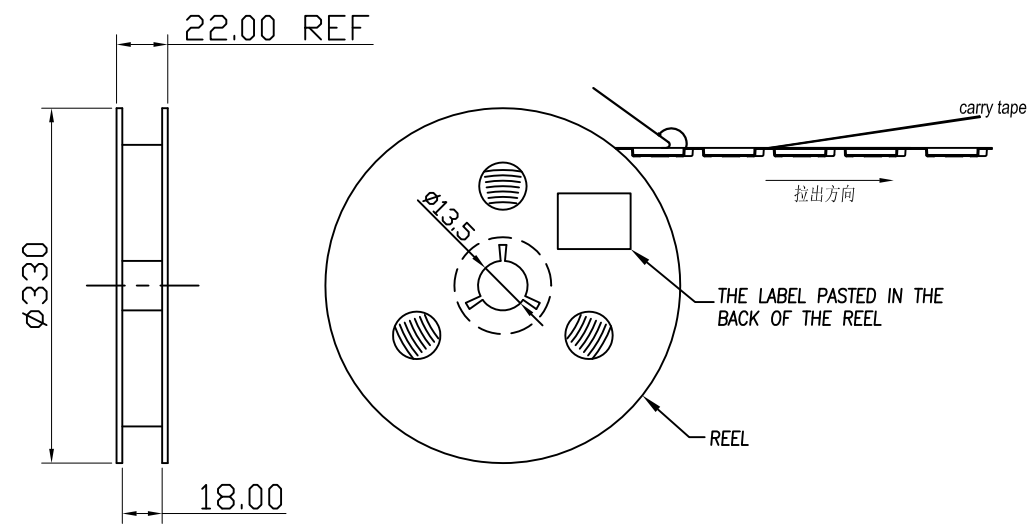
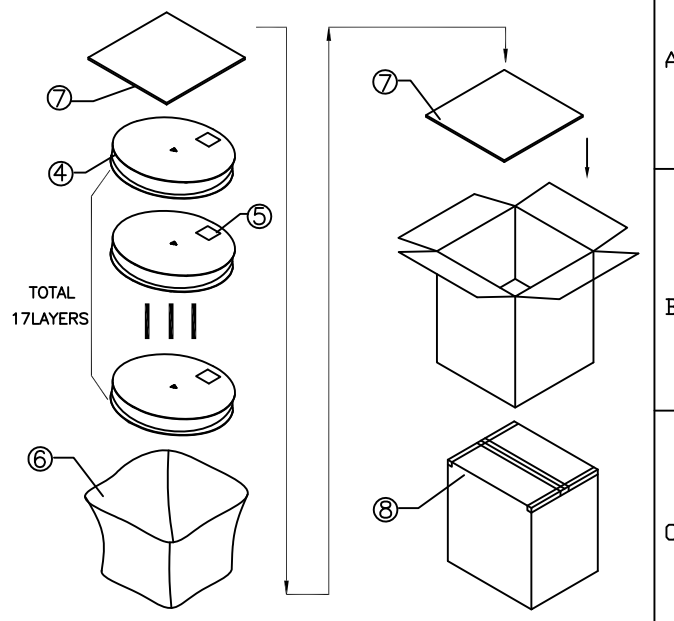
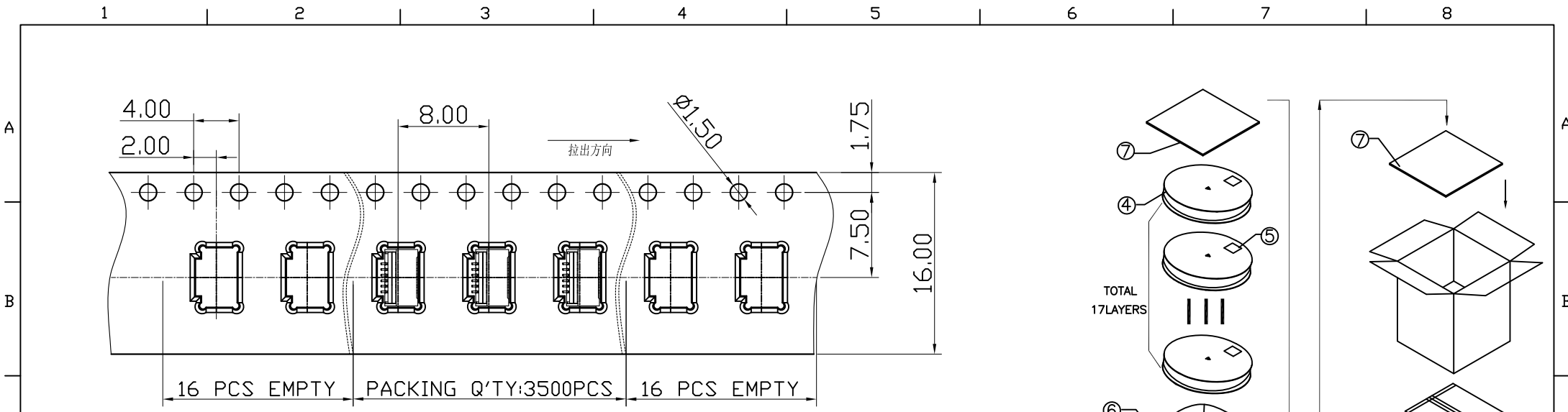

BOM:

| NO. | NAME       | P/N            | SPEC.                 | Q'TY     |
|-----|------------|----------------|-----------------------|----------|
| ①   | ZF-CONN.   | ZF2-ABXXF10A   | PITCH=0.50mm ZF CONN. | 59500PCS |
| ②   | CARRY TAPE | R16-ZF201XX0   | PS,W=16.0,P=8.0       | 482.8m   |
| ③   | COVER TAPE | C16-01000004-K | PE,W=13.3,T=0.05      | 482.8m   |
| ④   | REEL       | P16-01100000   | $\phi 330,H=16.0$     | 17PCS    |
| ⑤   | LABEL      | L01-01000000   |                       | 17PCS    |
| ⑥   | PE袋        | G01-00907007   | 900*700               | 1PCS     |
| ⑦   | 隔板         | Y03-40036000   | 400*360*3             | 2PCS     |
| ⑧   | 纸箱         | W01-01353539   | 350*350*390           | 1PCS     |

| P/N          |
|--------------|
| ZF2-AB06F10A |
| ZF2-AB08F10A |

| REV. | ECN NO.   | DESCRIPTION | DATE       | UNITS:<br>mm      | GENERAL TOLERANCE   | DRAW:  | PART NO:                             |
|------|-----------|-------------|------------|-------------------|---|--|--------------------------------------|
| A    | E1809372A | NEW         | 09/06'2018 | DATE:<br>09/06'18 | X. $\pm 0.30$<br>.X $\pm 0.20$<br>.XX $\pm 0.10$<br>.XXX $\pm 0.05$ | X.* $\pm 2.00^*$<br>.X.* $\pm 1.00^*$<br>.XX.* $\pm 0.50^*$<br>.XXX.* $\pm 0.10^*$ | ZF2-ABXXF10A                         |
|      |           |             |            | SCALE:<br>1/1     |   | CHECKED:   | TITLE:<br>0.50PITCH ZF CONN. PACKING |
|      |           |             |            | SHEET:<br>1/1     |   | APPROVE:   | DRAWING NO:                          |
|      |           |             |            | REV.<br>A         | MATERIAL:<br>SEE NOTE   |  |                                      |

